



Ventilation grille Ib



Ferdinand Schad KG
Steigstraße 25 - 27
78600 Kolbingen
Telefon (07463) 980 - 0
Telefax (07463) 980 - 200
info@schako.de



**Ib****Ventilation grille****Contents**

Description	3
Construction	3
Model	3
Accessories	3
Fixing	3
Models and dimensions	
Dimensions	4
Accessories - dimensions	6
Fixing possibilities	9
Technical data	
Pressure loss and noise level	10
Maximum end velocity	13
Air path	14
Critical throw	15
Maximum penetration	16
Induction ratio	17
Further datas	17
Legend	20
Specification texts	21

**lb**

Ventilation grille

Description

Supply and return air grille with horizontal or vertical adjustable blades. Frame and blades made from stove enamelled sheet steel RAL 9010 (white) or from galvanised sheet steel. Assembly parts made from galvanised sheet steel. Screw mounting (SM) as standard.

Construction

frame and blades

- painted sheet steel RAL 9010 (white) (standard)
- galvanised sheet steel
- painted sheet steel, in any other RAL colour

Model

lb 1 - with horizontal adjustable deflection blades
lb 2 - same as lb 1, with vertical punched out grille
lb 8 - same as lb 2, with hit and miss damper
lb 8c - same as lb 1, with vertical punched out grille and hit and miss damper
lb 10 - with vertical adjustable deflection blades
lb 11 - same as lb 10, with horizontal deflection blades
lb 15 - same as lb 10, with hit and miss damper
lb 16 - same as lb 10, with horizontal adjustable blades and hit and miss damper

Accessories

plenum box (-ASK) - galvanised sheet steel
mounting frame (-E1) - galvanised sheet steel

Fixing

screw fixing (-SM) - standard
secret fixing (-VM) - at extra cost



Ib

Ventilation grille

Models and dimensions

Dimensions

Ib 1

single deflection horizontal blades

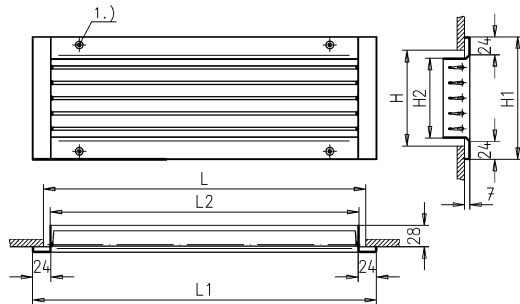

from length 825 with support bar (see page 10)
1.) for countersunk screws DIN ISO 7051 ST 3.9

all models are made from the basis type Ib 1

Ib 2

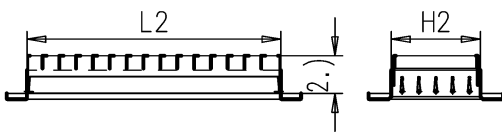

Ib 8

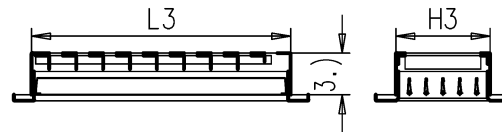

Ib 8c

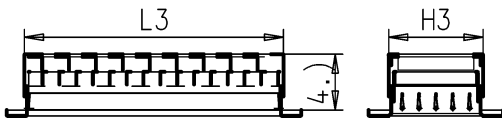

1.) countersunk screw
DIN ISO 8051 ST 3,9

2.) SM = 45 or VM = 55

size 400 not available with saddle bracket

x not available

3.) SM = 50 or VM = 65

4.) SM = 65 or VM = 65

Available sizes

L	L1	L2	L3	H	H1	H2	H3
325	350	307	310	125	160	107	110
425	450	407	410				
525	550	507	510	225	260	207	210
625	650	607	610				
825	850	807	810	325	360	307	310
1025	1050	1007	1010				

All lengths and heights combinable!



Ib

Ventilation grille

Ib 10,
single deflection vertical blades

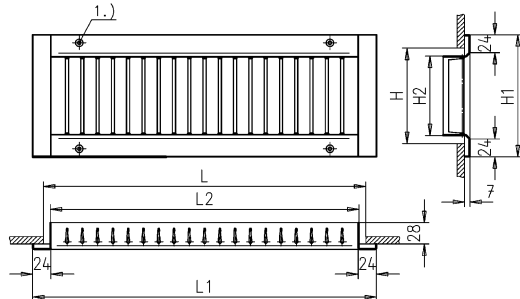

all models are made from the basic type Ib 10

Ib 11

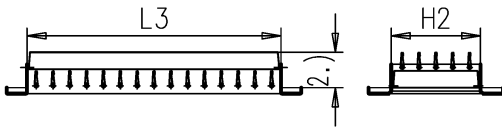

Ib 15

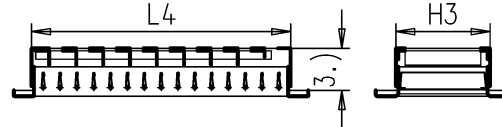

Ib 16

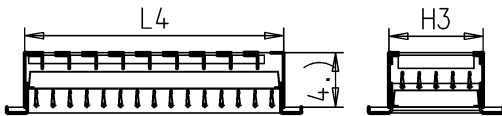

- 1.) countersunk screw
DIN ISO 8051 ST 3,9
- 2.) SM = 42 or VM = 55
size 400 not available with saddle bracket
x not available
- 3.) SM = 50 or VM = 65
- 4.) SM = 65 or VM = 65

Available sizes

L	L1	L2	L3	L4	H	H1	H2	H3
325	350	307	309	310	75	110	56	60
425	450	407	409	410				
525	550	507	509	510	125	160	106	110
625	650	607	609	610	225	260	206	210
825	850	807	809	810	325	360	306	310
1025	1050	1007	1009	1010				

All lengths and heights combinable!



lb

Ventilation grille

Accessories - dimensions

Plenum box (-ASK)

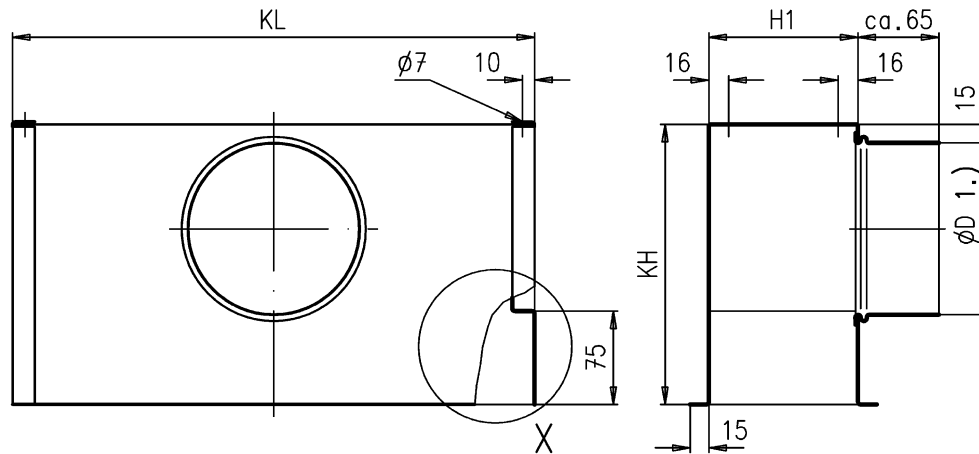

1.) Outside

Grilles can not be fitted with hit and miss damper if a plenum box is attached, i.e. it can either be fitted with a damper or a plenum box

Detail X

size 400 not available with saddle bracket
x not available

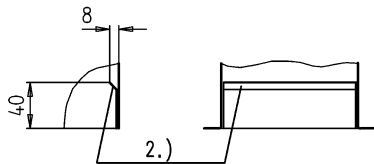

2.) lugs only with VM fixing



lb

Ventilation grille

Available sizes

L	H	KL	H1	KH	øD	L	H	KL	H1	KH	øD
325	75	320	68	210	123	325	125	320	118	245	158
425		420		210	123	425		245		158	
525		520		210	123	525		245		158	
625		620		210	123	625		245		158	
825		820		245	158	825		285		198	
1025		1020		245	158	1025		285		198	

L	H	KL	H1	KH	øD	L	H	KL	H1	KH	øD
325	225	320	218	285	198	325	325	320	318	335	248
425		420		285	198	425		335		248	
525		520		285	198	525		335		248	
625		620		335	248	625		400		313	
825		820		335	248	825		400		313	
1025		1020		335	248	1025		400		313	

Mounting frame (-E1)

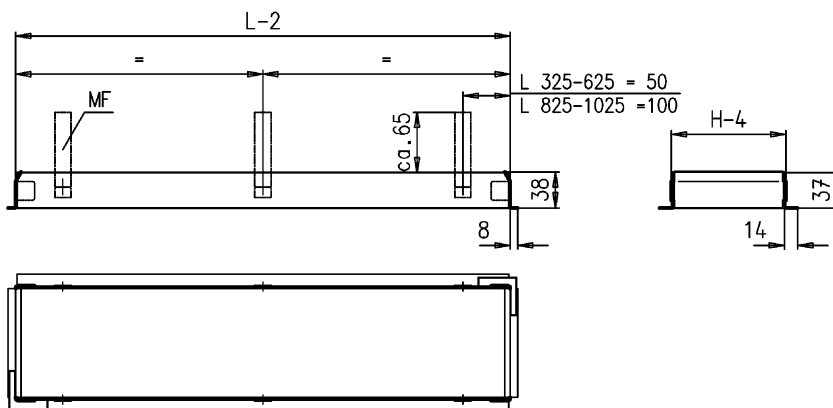

MF = wall anchors available at extra cost
 length $L < 825$ mm = 4 wall anchors
 length $L > 825$ mm = 6 wall anchors

Mounting frame for continuous run two sections, $BL \leq 2025$ mm

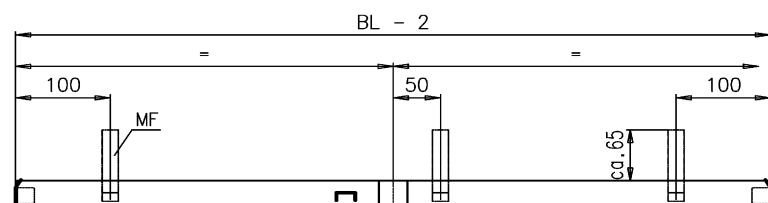



Ib

Ventilation grille

BL > 2025 mm , several sections

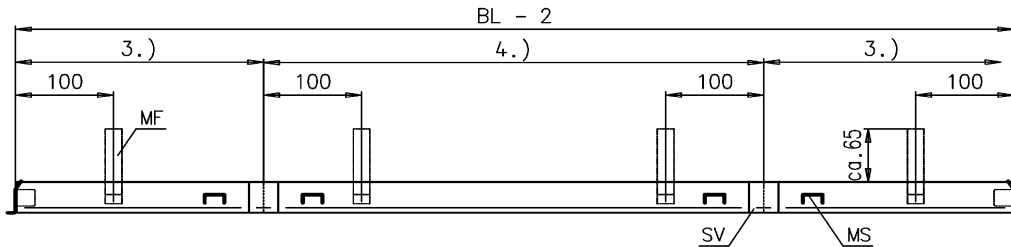

- BL = Strip length
- MF = Wall anchor
- SV = Plug connection
- MS = Assembly web

Mounting frames for continuous runs are supplied with plug connections. Assembly webs are additionally attached, switch can easily be removed with a turn, once the grille is walled in.
All mounting frames are supplied without wall anchors as standard. They are available at extra cost.

Ib as continous run

grille types Ib 10, Ib 11, Ib 15 and Ib 16 are available as a continuous run. continuous runs are only available with a screw fixing (SM)

continuous run, in 2 sections if BL < 2025 mm

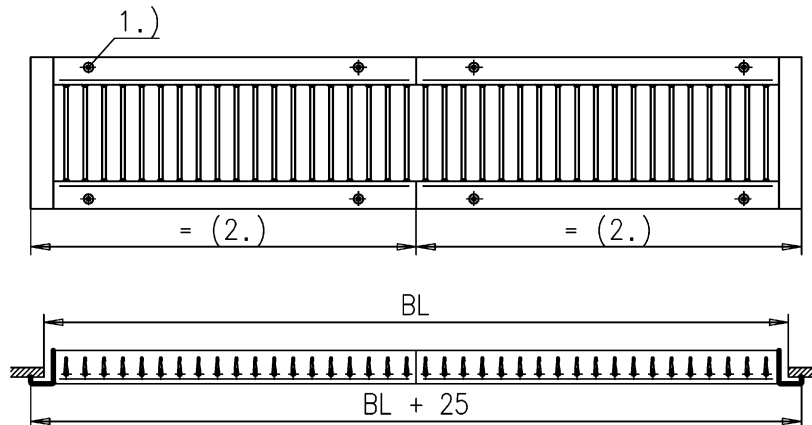



lb

Ventilation grille

continuous run in several sections if $BL > 2025$ mm

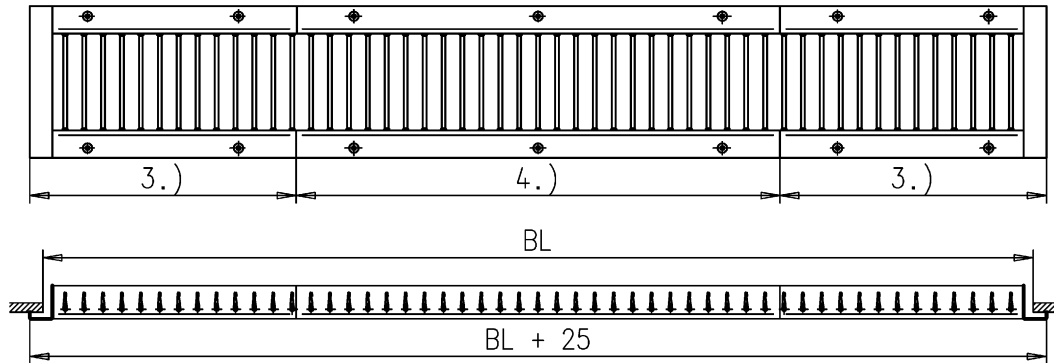

end piece < 425 mm = 4 screws

end piece > 425 mm = 6 screws

middle section 6 screws

3.) end piece 1/2 difference

4.) part section(s) 1020

Fixing possibilities

screw fixing (SM)

screw fixing (SM) is supplied as standard unless specified otherwise

L 325-425

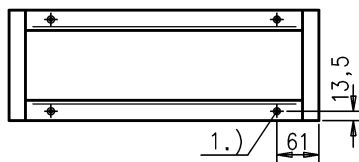

L 525-625

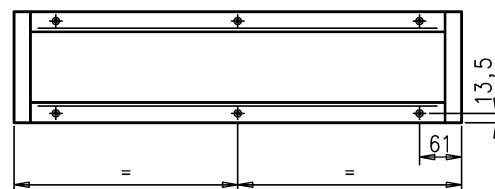

L 825-1025

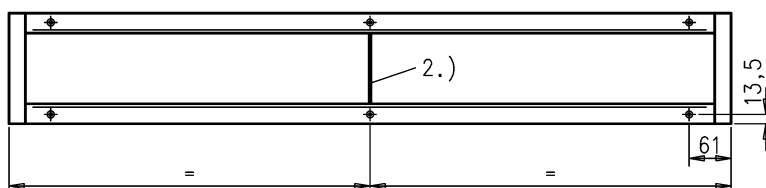

1.) countersunk for screws DIN ISO 7051 ST 3.9

2.) support bar with lb grille with horizontal blades



lb

Ventilation grille

Secret fixing (VM) (at extra cost)
 (not possible with lb 8, lb 8c, lb 15, lb 16)

Grille type lb is available with a secret fixing (VM) at extra cost. VM 12 is standard if a secret fix is required without a mounting frame E1.
 Secret fixing VM 11 and VM 12 is only available with a mounting frame. The mounting frame must be ordered separately.

from height 225 each side
2 fixings

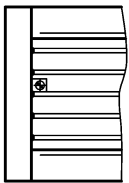

VM 11

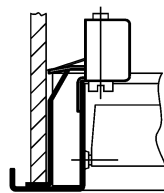

only available with mounting frame

VM 12

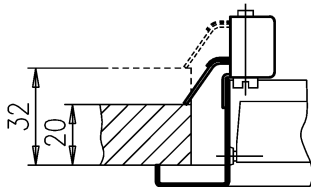

VM 13

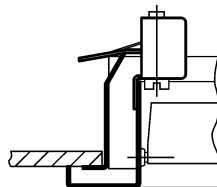

only available with mounting frame



lb

Ventilation grille

Technical data

Pressure loss and noise level

supply air face velocity

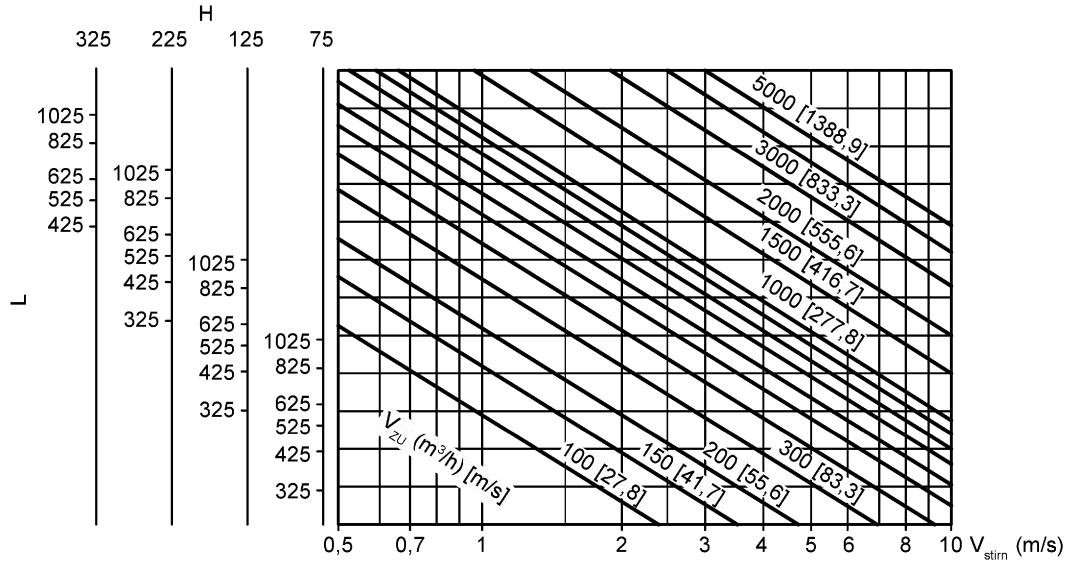

lb (supply air)

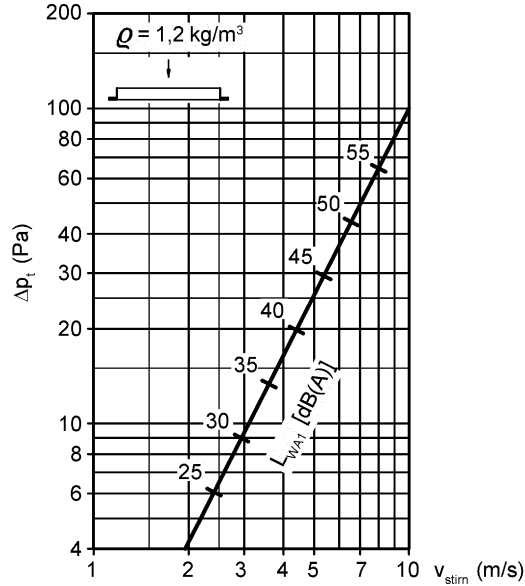

lb with hit and miss damper (supply air)

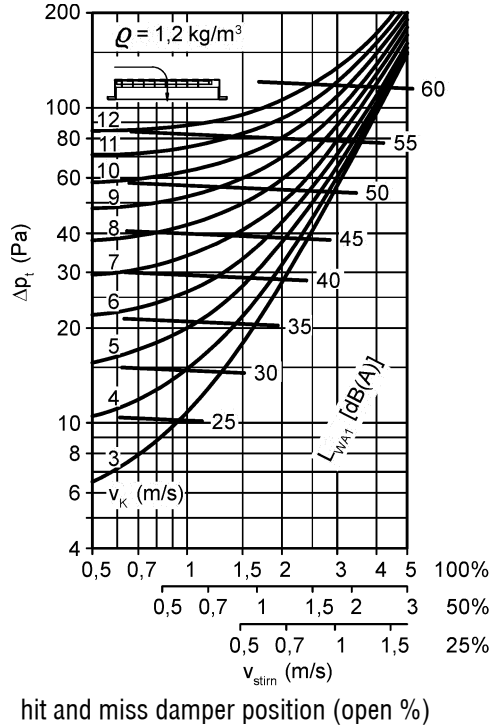



lb

Ventilation grille

extract air face velocity

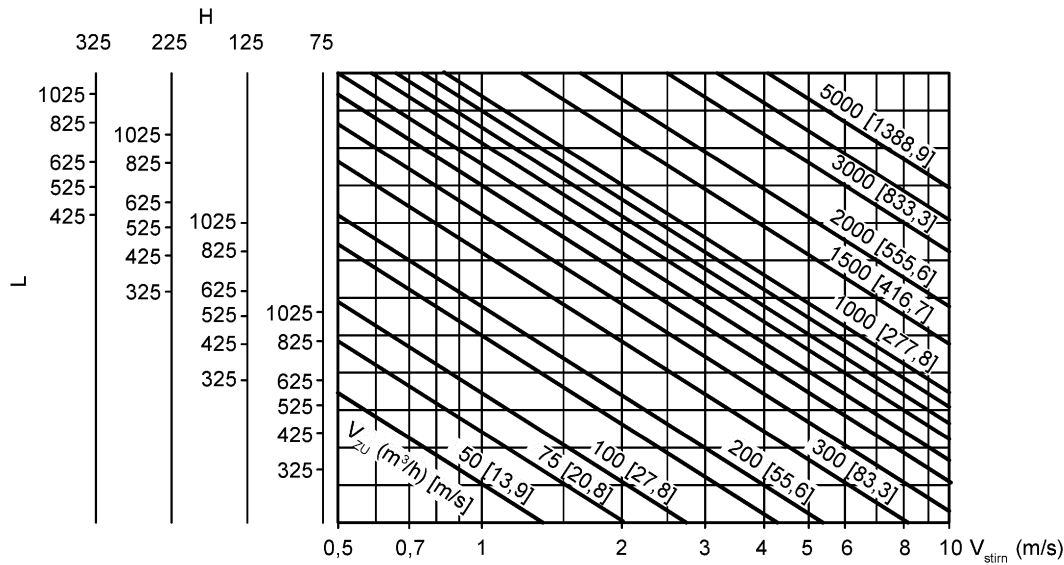

lb (extract air)

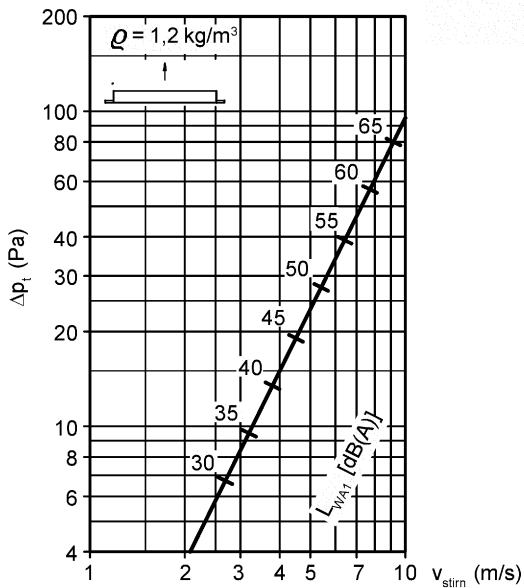

lb with hit and miss damper (extract air)

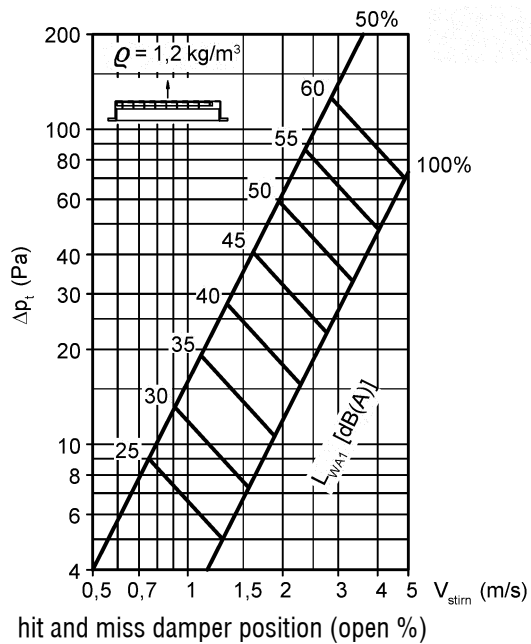

Extract and supply air face area (m²)

H	L					
	325	425	525	625	825	1025
75	0,016	0,021	0,026	0,031	0,042	0,052
125	0,031	0,041	0,051	0,061	0,082	0,102
225	0,061	0,081	0,101	0,122	0,162	0,202
325	-	0,121	0,151	0,182	0,242	0,313



lb

Ventilation grille

Correction factor

lb supply air

$A_{stirn} (m^2)$	0,012	0,025	0,05	0,1	0,16	0,2	0,4
KF (-)	-9	-6	-3	0	+2	+3	+6

Extract air

$A_{stirn} (m^2)$	0,012	0,025	0,05	0,1	0,16	0,2	0,4
KF (-)	-9	-6	-3	0	+3	+6	+7

Maximum end velocity

supply air without coanda effect

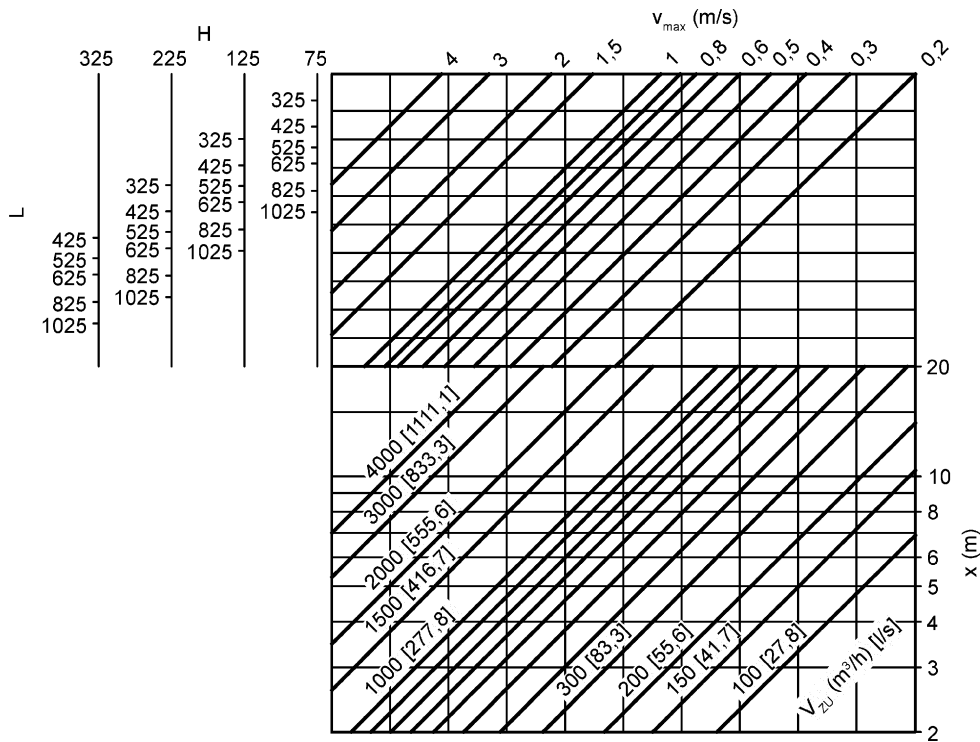



lb

Ventilation grille

supply air with coanda effect

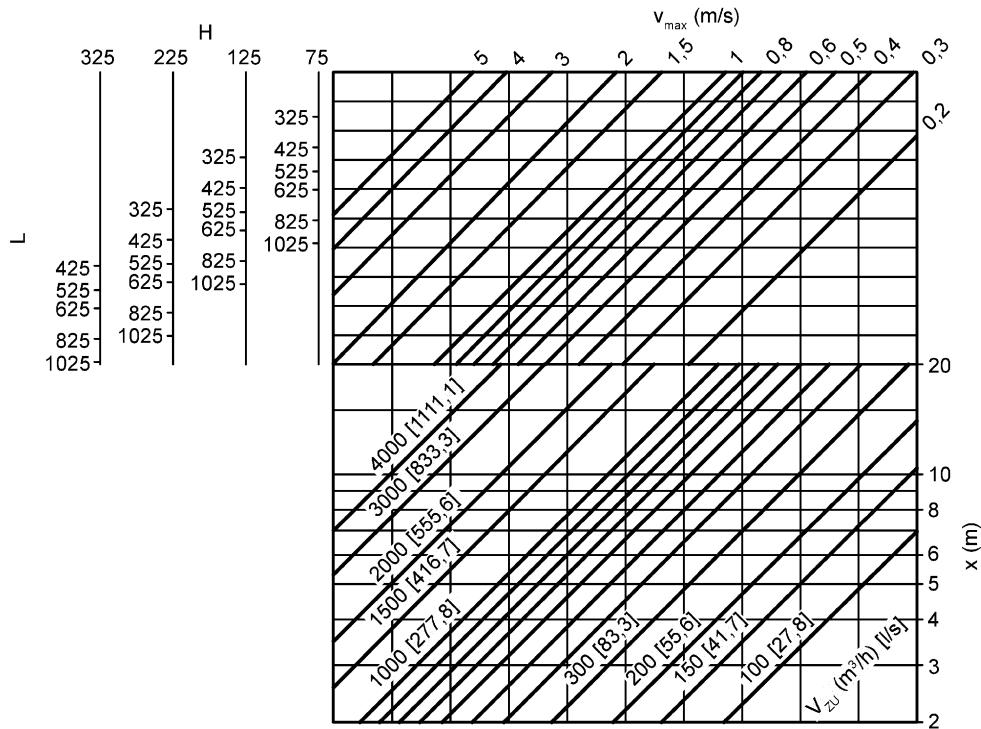

Air path

supply air without coanda effect

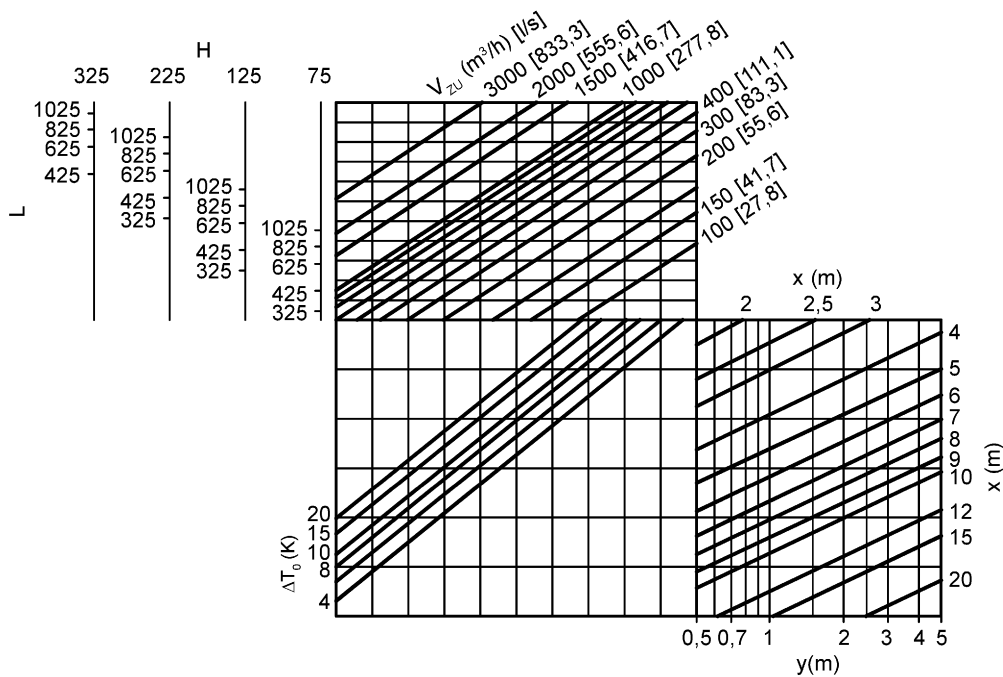



lb

Ventilation grille

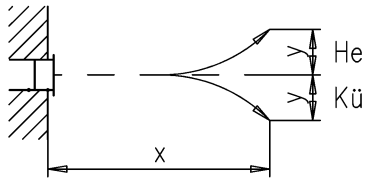

H = heating
K = cooling

Critical throw

supply air with conda effect
detachment from ceiling

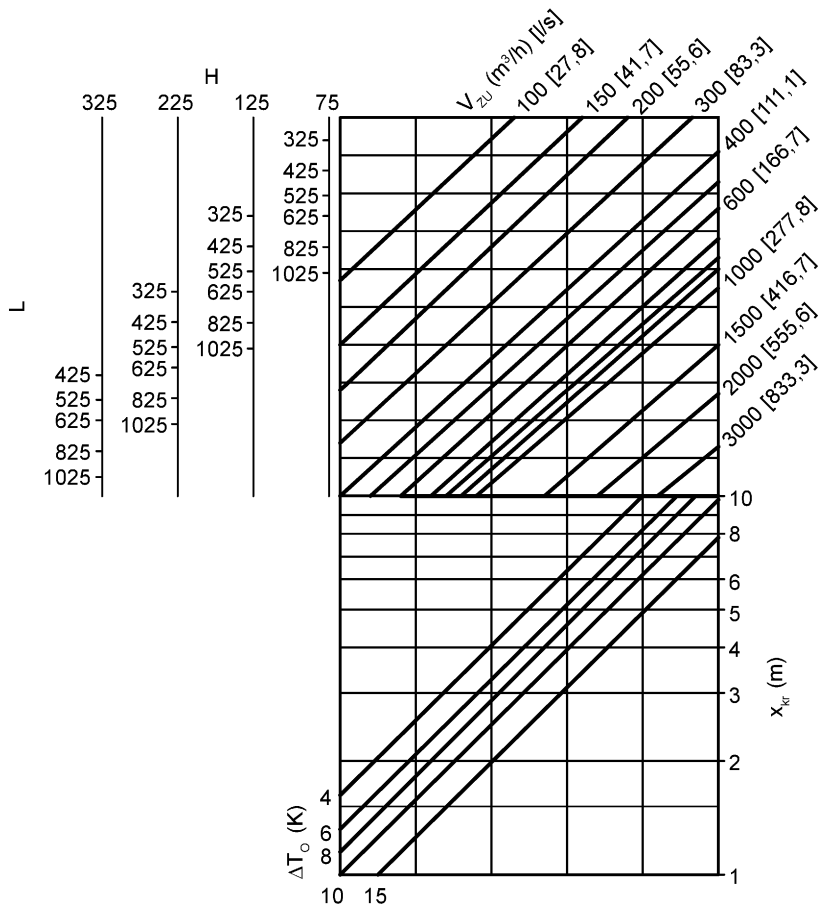



Ib

Ventilation grille

detachment from ceiling

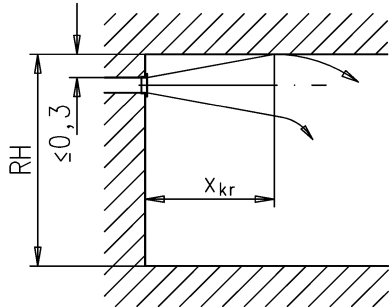

Maximum penetration

heating mode

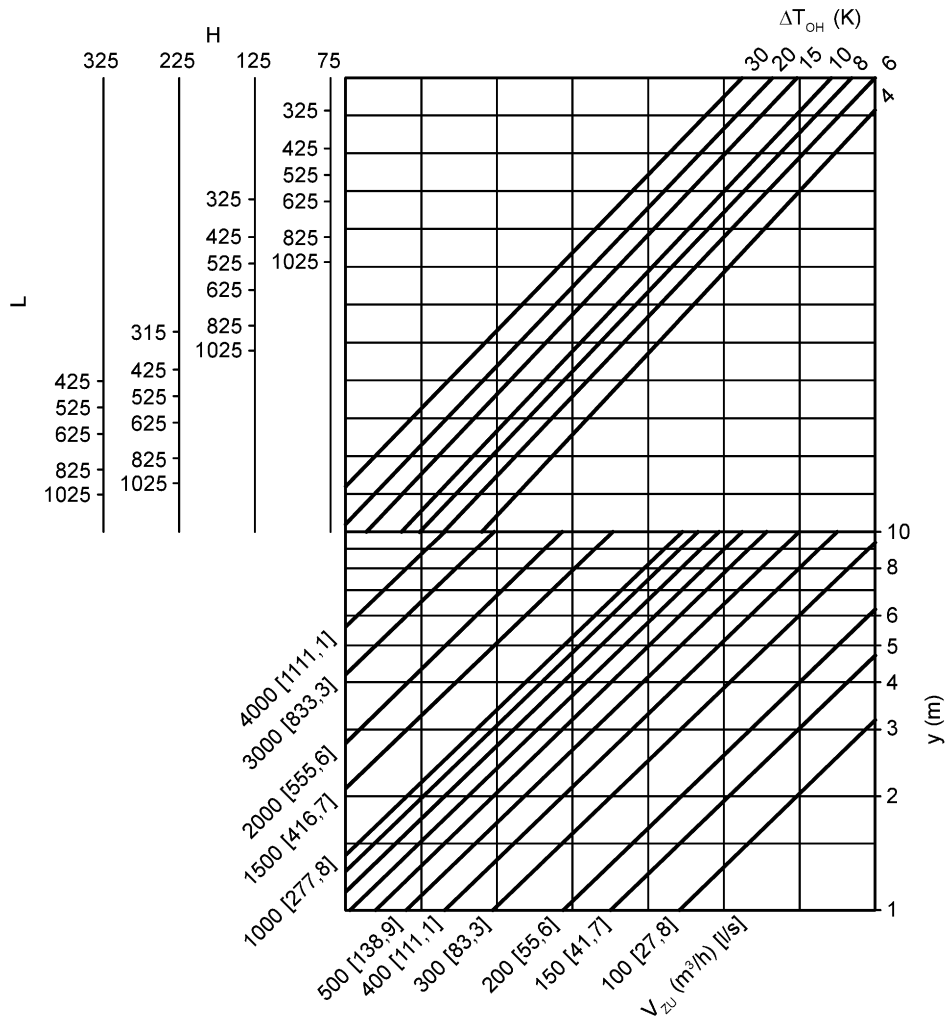



lb

Ventilation grille

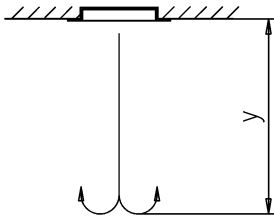

Induction ratio

supply air without coanda effect
induction and temperature ratio

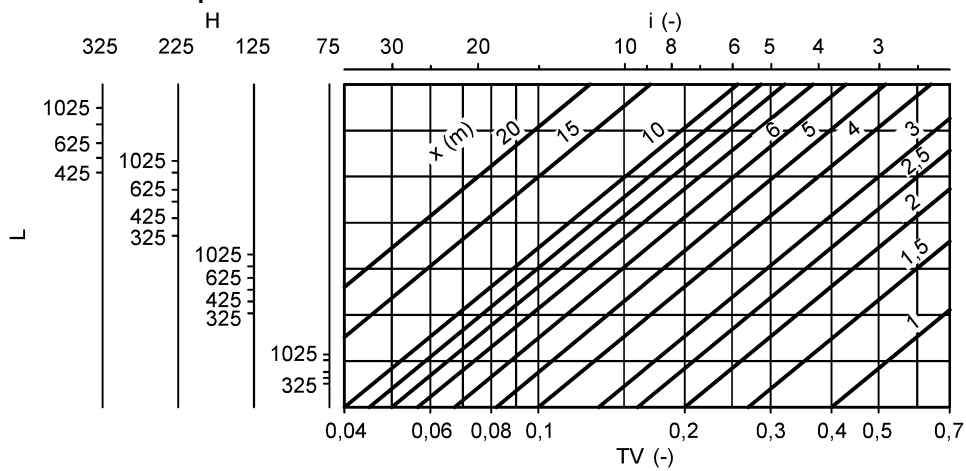

supply air with coanda effect

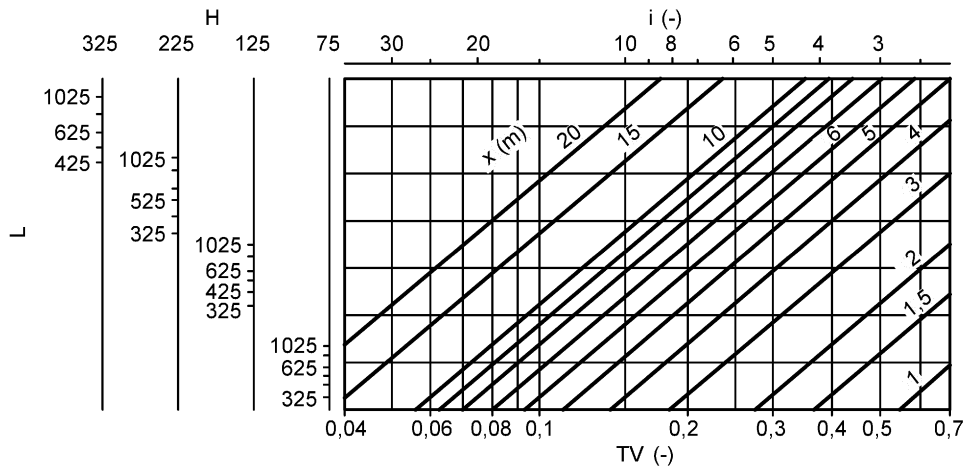



Ib

Ventilation grille

Further datas

minimum distance apart:
supply air without coanda effect

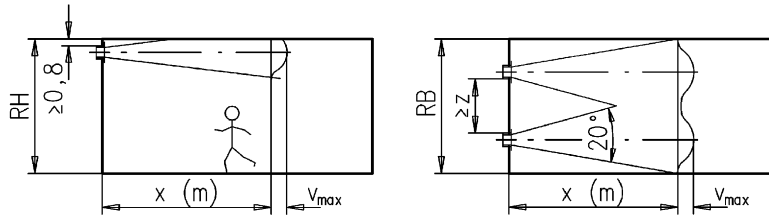

supply air with coanda effect

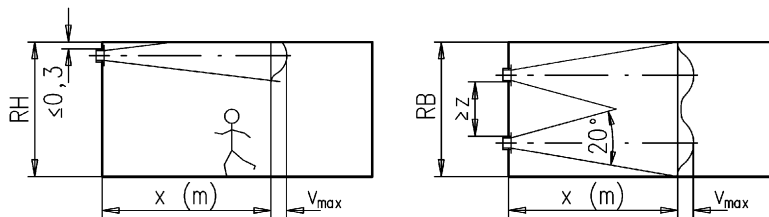

if the distance between grilles "D" is less than $(x \cdot 0.2)$ then we refer to a continuous grille

Correction factor (for diverted jet)

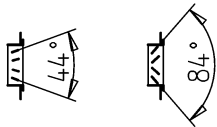

Blade position

	44 °	84 °
jet velocity	$v_{max} \text{ (m/s)} \times 0,65$	$v_{max} \text{ (m/s)} \times 0,5$
TV $\Delta T_z / \Delta T_o$	$\times 0,65$	$\times 0,5$
induction ratio	$i \times 1,3$	$i \times 2$
jet drop / rise	$y \times 1,3$	$y \times 2$
grille distance $z(m) >$	$x \times 0,20$	$y \times 0,25$



lb

Ventilation grille

Selection example:

given: grille type lb 8

- H = 125 mm
- L = 625 mm (with coanda)
- V_{supp} = 400 m³/h
- Δt = 4 K
- x = 6 m

look for : pressure drop, noise level, jet velocity, critical jet, induction and temperature ratios

result: pressure drop page 10
noise level page 10

- Δp_1 = 22 Pa
- v_{face} = 1,8m/s
- L_{wa1} = 36 dB(A)
- L_{wa} = 36 dB(A) - 2 = 34

jet velocity page 13
critical throw page 15
induction ratio page 17
temp ratio page 17

- v_{max} = 0,5 m/s
- x_{cr} = 5,80 m
- i = 7,5
- TV = 0,2

blades set straight



blade position 44° diverging

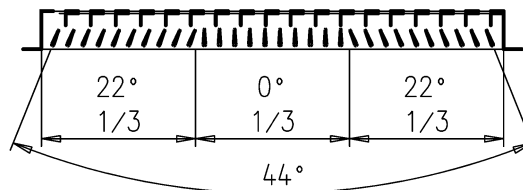

blade position 84° diverging

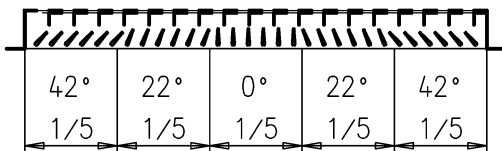

blade position 110° diverging

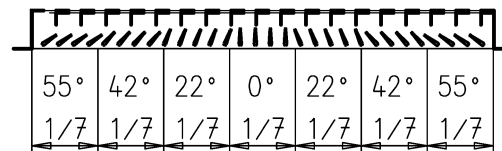



lb

Ventilation grille

blade position 140° diverging

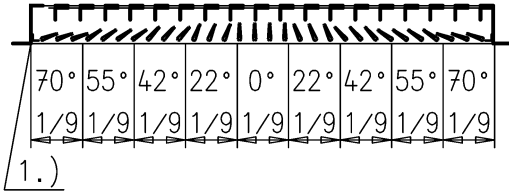

blade position set against each other



1.) first and last slot covered

The throw can be altered by adjusting the vertical blades.

blades set straight

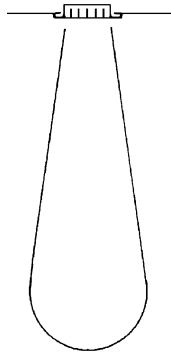

blades set diverging

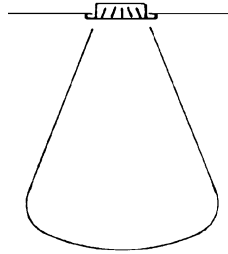



Ib

Ventilation grille

legend

V (m^3/h)	=	volume
W_k (m/s)	=	duct velocity
w_m (m/s)	=	max jet velocity
w_{face} (m/s)	=	exit velocity relative to A_{face}
x (m)	=	horizontal throw
x_{kr} (m)	=	critical throw
y (m)	=	jet drop / rise
i	=	induction ratio
i	=	V_k/V_o
V_x (m^3/h)	=	total air volume at point x
V_o (m^3/h)	=	supply air volume
ΔT_x (K)	=	temperature difference at point x
ΔT_{OH} (K)	=	temperature difference between room and supply air
ΔT_{OH} (K)	=	temperature difference at the grille face
ΔT_{OK} (K)	=	temperature difference in cooling mode
D (m)	=	minimum distance between grilles ($x \cdot 0.2$)
Δp_1 (Pa)	=	pressure loss
L_{WA1} (dB(A))	=	A weighted sound power level related to A_{face}
L_{WA}	=	$L_{WA1} + KF$
KF (dB(A))	=	correction factor
A_{face} (m^2)	=	face area
L	=	length
B	=	width
H	=	height
He	=	heating
Ku	=	cooling



Ib

Ventilation grille

Specification texts

Supply and extract grille **type Ib 1** comprising front frame with screw mounting (SM), with frontal pivoting horizontal air deflection plates.

Frame and blades enamelled sheet steel, colour RAL 9010 (white) or from electrolytically galvanised sheet steel. Assembly parts are made from electrolytically galvanised sheet steel.

Manufacturer: SCHAKO **type Ib 1**

- **Type Ib 2**, additionally with vertical punched out grille
- **Type Ib 8**, additionally with hit and miss damper
- **Type Ib 8c**, additionally with vertical punched out grille and hit and miss damper
- With masked assembly **VM 11** and mounting frame (-E1)
- With masked assembly **VM 12**
- With masked assembly **VM 13** and mounting frame (-E1)

Accessories:

- With plenum box (-ASK) made of galvanised steel.
- With assembly frame (-E1), made of electrolytically galvanised sheet steel.

Supply and extract grille **type Ib 10** with vertical adjustable blades, with screw fixing (SM).

frame and blades from stove enamelled sheet steel RAL 9010 (white) or from galvanised sheet steel. assembly parts are made from galvanised sheet steel.

Manufacturer: SCHAKO **type Ib 10**

- **Type Ib 11**, additionally with horizontal pivoting assembled blades
- **Type Ib 15**, additionally with hit and miss damper
- **Type Ib 16**, additionally with additional horizontal, pivoting assembled blades and hit and miss damper
- With masked assembly **VM 11** and mounting frame (-E1)
- With masked assembly **VM 12**
- With masked assembly **VM 13** and mounting frame (-E1)

Accessories:

- With plenum box (-ASK) made of galvanised steel.
- With assembly frame (-E1), made of electrolytically galvanised sheet steel.

supply and extract air continuous run type Ib made up of 2 or more sections with vertical front blades with screw fixing (SM).

frame and blades from stove enamelled sheet steel RAL 9010 (white) or from galvanised sheet steel. assembly parts are made from galvanised sheet steel.

Manufacturer: SCHAKO type Ib 10 (continuous run)

- type Ib 11, with additional horizontal adjustable blades
- type Ib 15, with hit and miss damper in 2 or more sections
- type Ib 16, with additional horizontal blades and damper
- mounting frame E 1 , from galvanised sheet steel in 2 or more sections